



STUDIO•M

2026 WINTER



# STUDIO•M

2026 WINTER



REFRESHINGLY MODERN, RETRO COOL



# VESTA BY MAT SANDERS

Symbolic of the hearth and home, the Vesta collection draws inspiration from the Roman goddess represented by the fire of her temple. Large diameters of shallow, inverted vessels disperse indirect light upward scattering softer, ambient light toward the ceiling. Purposeful in design and its applications, a Dim-to-Warm feature is integrated into the LED light engine so that as you set the lighting dimmer past , the light emitted becomes warmer and more relaxing. Highly reflective, polished metal finishes of rich French Gold or cool Polished Chrome elevate the minimalistic forms with vibrancy, while dramatic two-tone options combining “Mat” White or “Mat” Black shades allow for more neutral compositions. Masterfully understated, Mat Sanders manages to create product and spaces that are both effortlessly sophisticated and pleasantly welcoming.



SM81858

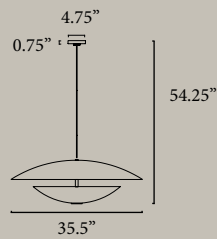

SM81858 • Two Tier Pendant

36W LED PCB (integrated)  
35.5"D x 11.5"H, 54.25" Max OA  
Canopy: 4.75"D x 0.75"  
CCT Select 3000-2700-2200K, CRI 90+

Available in:  
Mat White w/ French Gold (MWFG)    Black with French Gold (BKFG)  
Weather Black (WBR)                      Black (BK)





SM81856



SM81854

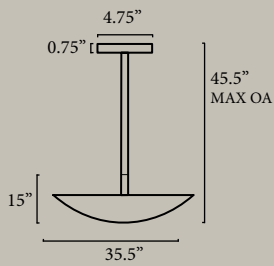

SM81856 • 36" Pendant / Semi-Flush

45W LED PCB (integrated)  
 35.5"D x 15.5"H, 45.5" Max OA  
 Canopy: 4.75"D x 0.75"  
 CCT Select 3000-2700-2200K, CRI 90+

Available in  
 Black with French Gold (BKFG)  
 Polished Chrome(PC) Weather Black (WBR)  
 French Gold (FG) Black (BK)

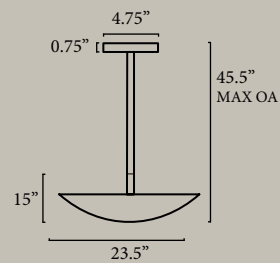

SM81854 • 24" LED Pendant / Semi-Flush

28W LED PCB (integrated)  
 23.5"D x 15"H, 45.5" Max OA  
 Canopy: 4.75"D x 0.75"  
 CCT Select 3000-2700-2200K, CRI 90+,

Available in  
 Black with French Gold (BKFG)  
 Polished Chrome(PC) Weather Black (WBR)  
 French Gold (FG) Black (BK)



SM81859



SM81850

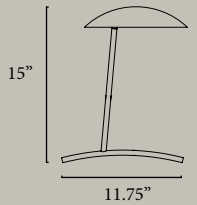

SM81859 • Desk Lamp

5W LED PCB (integrated)  
 9.75" W x 15" H, 11.75" L  
 CCT Select 3000-2700-2200K, CRI 90+

Available in  
 Black with French Gold (BKFG)  
 Polished Chrome (PC) Weather Black (WBR)  
 French Gold (FG) Black (BK)

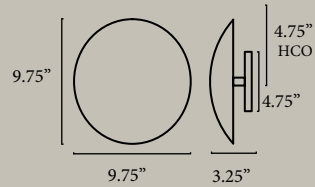

SM81850 • 10" LED Flush Mount

15W LED PCB (integrated)  
 9.75" W x 9.75" H x 3.25" E  
 BP: 4.75" D x 0.75", 4.75" HCO  
 CCT Select 3000-2700-2200K, CRI 90+

Available in  
 Black with French Gold (BKFG)  
 Polished Chrome (PC) Weather Black (WBR)  
 French Gold (FG) Black (BK)





# FOLD BY MAT SANDERS

A understated form with dramatic effect, Mat Sanders applies his expertise at subtleties in luxurious design. A single fold of brushed Natural Aged Brass gently folds over concealing an LED light source within. The light source is surprisingly powerful as it casts ample illumination downward in a warm hue that creates a softer ambience to a space.



SM81830

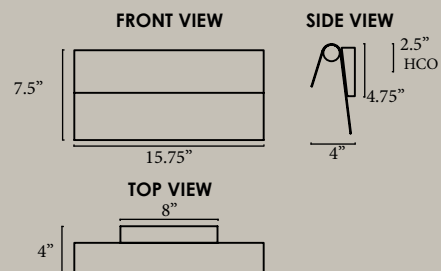

SM81830 • Sconce

18W LED DC (integrated)  
15.75"W x 7.5"H, 4"E  
BP: 8"L x 4.75"H, 2.50" HCO  
3000K, CRI 90+, 1030 lm

Available in Natural Aged Brass (NAB)



# FACETS BY MAT SANDERS

With simple linear compositions and an elongated curved form, Mat Sanders draws inspiration from the Streamline Modern era of the 1930s. The faceted opal white glass elegantly diffuses light, while solid brass details provide an elevated, timeless look. Select from 5 color temperatures by adjusting the toggle switch easily accessible behind the shade.



SM21362



SM21363



SM21364

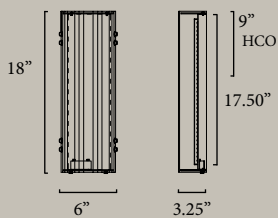

SM21362 • 18" Vanity

25W LED PCB (integrated)  
 6" W x 18" H x 3.25" E  
 BP: 4.75" W x 17.50" H, 9" HCO  
 CCT: 27-30-35-40-50K  
 CRI 90+, 2880 lm

Available in White with either Natural Aged Brass (WTNAB) or Polished Nickel (WTPN)

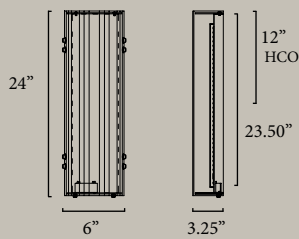

SM21363 • 24" Vanity

28W LED PCB (integrated)  
 6" W x 24" H x 3.25" E  
 BP: 4.75" W x 23.50" H, 12" HCO  
 CCT: 27-30-35-40-50K  
 CRI 90+, 3180 lm

Available in White with either Natural Aged Brass (WTNAB) or Polished Nickel (WTPN)

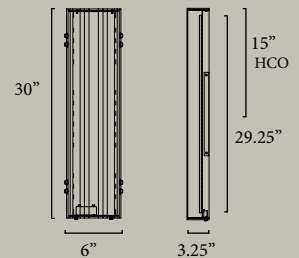

SM21364 • 30" Vanity

40W LED PCB (integrated)  
 6" W x 30" H x 3.25" E  
 BP: 4.75" W x 29.25" H, 15" HCO  
 CCT: 27-30-35-40-50K  
 CRI 90+, 4650 lm

Available in White with either Natural Aged Brass (WTNAB) or Polished Nickel (WTPN)

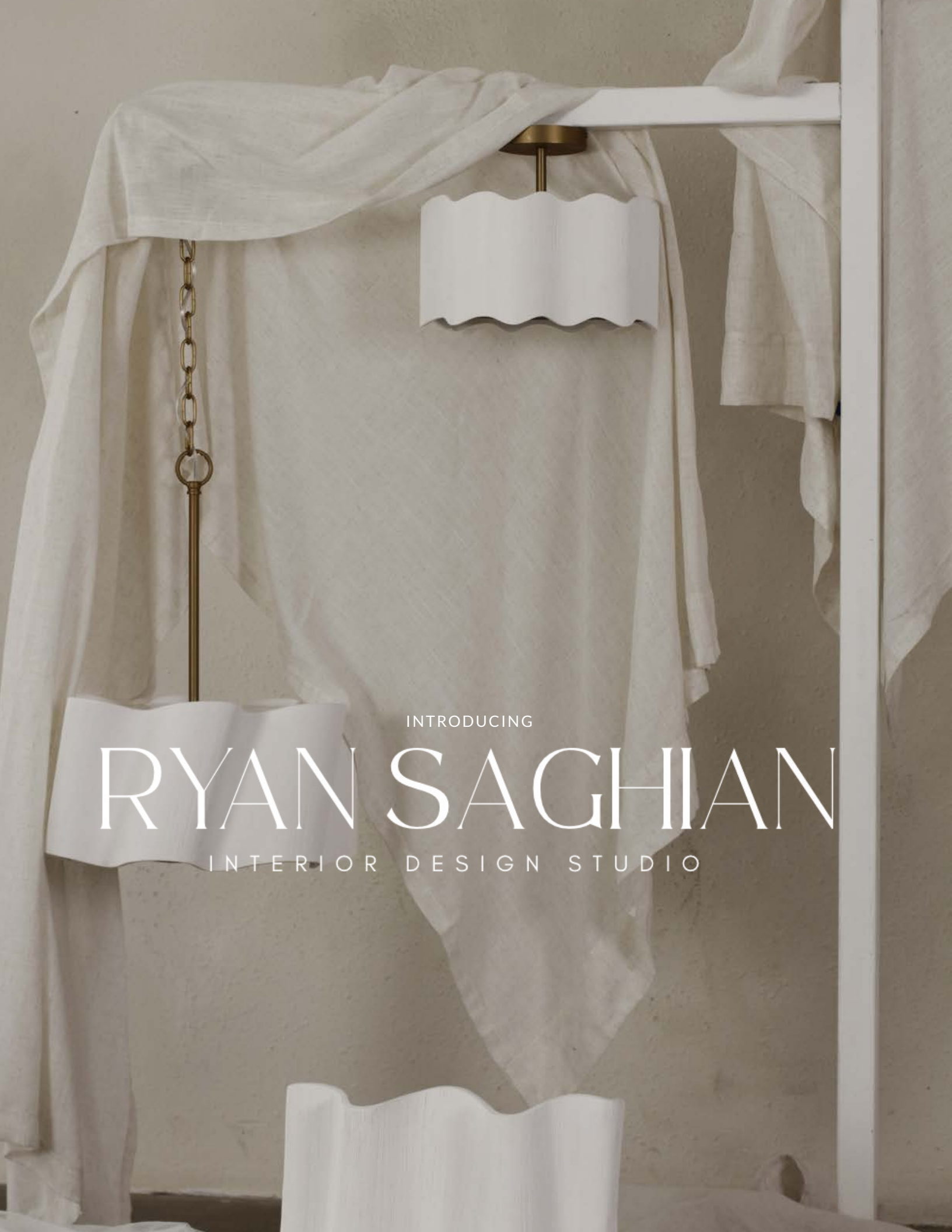

INTRODUCING

# RYAN SAGHIAN

INTERIOR DESIGN STUDIO

An embodiment of artistry, passion, and a commitment to pushing boundaries. Interior Design Ryan Saghian is an internationally acclaimed, award winning architectural interior design firm specializing in high-end residential and hospitality projects. Recognized for a diverse and wide-ranging portfolio encompassing a symphony of rich, unexpected materials that exist between opulence and raw authenticity. Eschewing a single signature style, we celebrate diversity, crafting spaces that encompass an array of aesthetics. With a signature touch that captivates those who seek the extraordinary, the team at Ryan Saghian Interiors transform spaces into living canvases that tell stories, drawing inspiration from the global tapestry of cultures and weaving intricate references with love and respect. With each project, we embark on a journey of transformation, redefining spaces into timeless narratives that reflect the essence of those who inhabit them.





# SHROUD BY RYAN SAGHIAN

Hand formed metal mesh shades are dimpled and folded into distinctive, artisanal forms. In more traditional lantern and chandelier configurations, these unique shades feature the material suspended within solid brass cages. A large modern, LED pendant features a mesh shade supported atop a sculpted travertine base with brass finial. Similarly, an oversized accent lamp features a large body of travertine at its base with a seemingly floating mesh shade perched atop a brass column. All fixtures include opal white LED lamps.



SM42402



SM42404

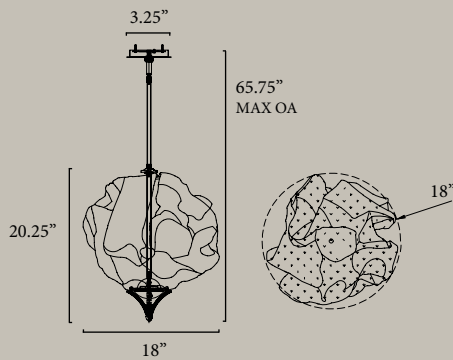

SM42402 • Chandelier

12W E12 LED Candelabra (included)  
 18"D x 20.25"H, 65.75" Max OA  
 Canopy: 6"D x 1"H  
 3000K, CRI 90+, 120 lm

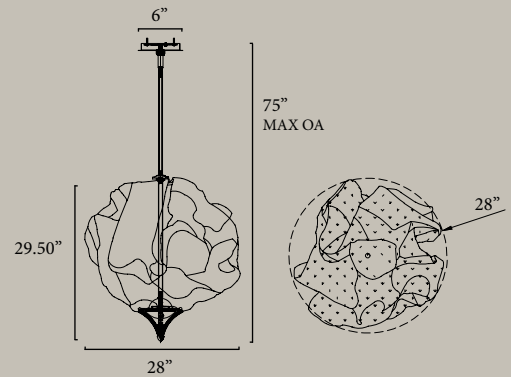

SM42404 • Chandelier

15W E12 LED Candelabra (included)  
 28"D x 29.50"H, 75" Max OA  
 Canopy: 6"D x 1"H  
 3000K, CRI 90+, 220 lm

Available in White with Natural Aged Brass (WTNAB)

Available in White with Natural Aged Brass (WTNAB)



SM42401

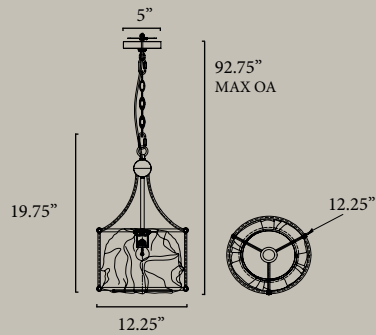

SM42401 • Pendant

6W E26 LED G25 (included)  
 12.25"D x 19.75"H, 92.75" Max OA  
 Canopy: 5"D x 1"H,  
 3000K, CRI 90+, 390 lm

Available in White with Natural Aged Brass (WTNAB)



SM42403

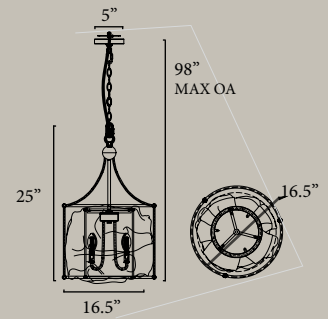

SM42403 • Pendant

(3) 4W E12 LED Candelabra (included)  
 16.50"D x 25"H, 98" Max OA  
 Canopy: 5"D x 1"H  
 3000K, CRI 90+, 380 lm

Available in White with Natural Aged Brass (WTNAB)



SM42409



SM42408

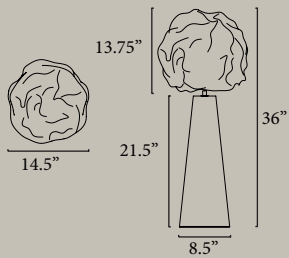

SM42409 • Accent Lamp

6W E26 LED G25 (included)  
 14.50"D x 36"H  
 3000K, CRI 90+, 400 lm

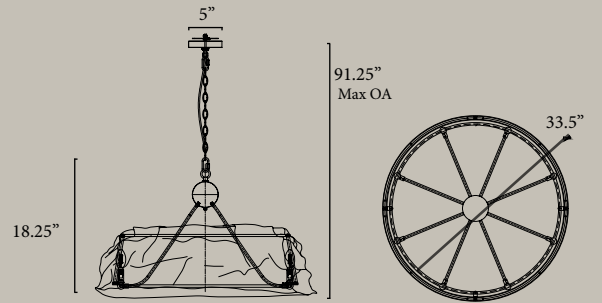

SM42408 • Chandelier

(8) 4W E12 LED Candelabra (included)  
 33.50"D x 18.25"H, 91.25" Max OA  
 Canopy: 5"D x 1"H  
 3000K, CRI 90+, 380 lm

Available in White with Natural Aged Brass (WTNAB)

Available in White with Natural Aged Brass (WTNAB)



# CURTAIN CALL BY RYAN SAGHIAN

Ryan Saghian captures the glamour of Hollywood evoked in plaster pendants with sculptural details. The forms appear to swell like a curtain, dramatic and striking. The fixtures create a mood in the evening with their soft, ambient light source and transform into a piece of art throughout the day. Thoughtful from every angle, the series features Polished Gold stainless steel mesh diffusers to conceal the light source below.



SM73880



SM73882

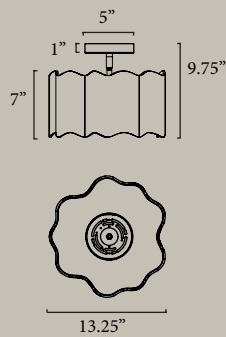

SM73880 • Semi - Flush

21W E26 Medium base (included)  
 13.25"D x 9.75"H  
 Canopy: 5"D x 1"H

Available in White with Gold (WTGLD)

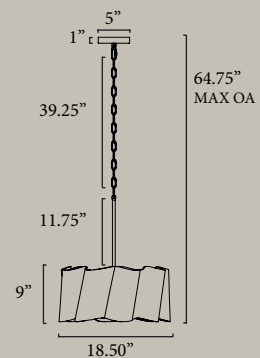

SM73882 • 20" Pendant

28W E26 Medium base (included)  
 18.50"D x 22.75"H, 64.75" Max OA  
 Canopy: 5"D x 1"H

Available in White with Gold (WTGLD)



SM73884



SM73883

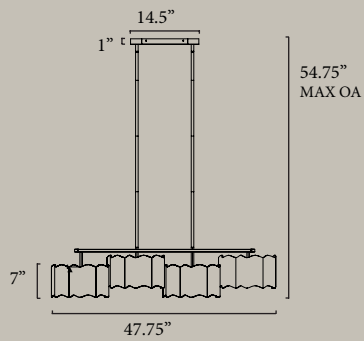

SM73884 • 4lt Pendant

21W E26 Medium base (included)  
 12.75"W x 11.25"H x 47.75"L, 54.75" MAX OA  
 Canopy: 4.75"W x 1"H x 14.50"L

Available in White with Gold (WTGLD)

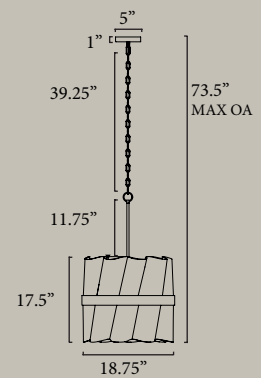

SM73883 • Foyer Light

21W E26 Medium base (included)  
 18.75"D x 31.25"H, 73.50" MAX OA  
 Canopy: 4.75"W x 1"H x 14.50"L

Available in White with Gold (WTGLD)

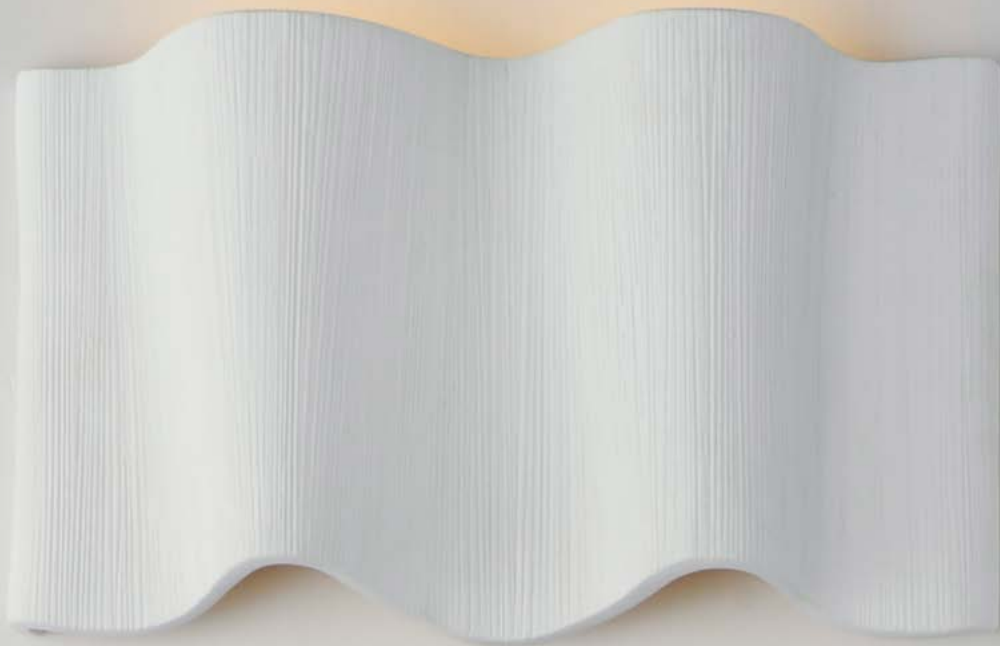

SM73881

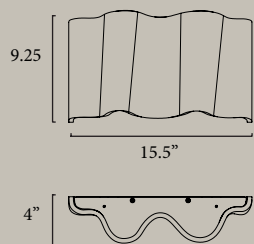

SM73881 • Sconce

8W E26 Medium base (included)  
15.50"W x 9.75"H x 4"E  
BP: 5.75"W x 0.75"H, HCO 4.75"

Available in White with Gold (WTGLD)





# NOMAD BY RYAN SAGHIAN

Inspired by a rugged landscape of the California coast, Ryan Saghian illustrates the journeying spirit the West. The oversized White plaster formation is striking in scale and contrasts the textured Anthracite finish on the large scaled candelabra that juts from this surface. The composition of the natural forms and rough textures relate a delicate balance of historical appreciation and modern beauty.



SM90210



SM90212

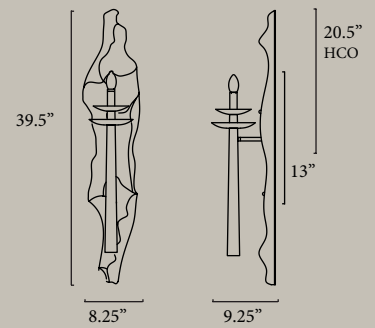
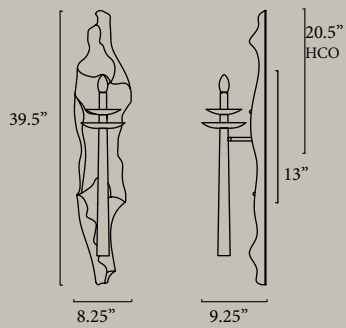

SM90210 • Sconce

4W E12 LED Candelabra (included)  
 8.25"W x 39.5"H x 9.25"E  
 BP: 4.25"W x 13.75"H, 20.50" HCO  
 3000K, CRI 90+, 400 lm

Available in White with Anthracite (WTAR)

SM90212 • Sconce

4W E12 LED Candelabra (included)  
 8.25"W x 39.5"H x 9.25"E  
 BP: 4.25"W x 13.75"H, 20.50" HCO  
 3000K, CRI 90+, 400 lm

Available in White with Anthracite (WTAR)



# STONEWALL MIRROR

BY NINA MAGON

Complimentary wall lighting products display the unique beauty of Spanish Alabaster and our Striae Arya stone panels in a modern application. Low-profile ADA sconce options in alabaster as well as illuminated mirrors and wall decor pair perfectly with the Megalith collection or stand alone to enhance a room's décor.



ADA

SM24800



ADA

SM24801

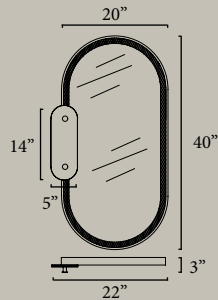

SM24800 • LED Mirror

35W LED PCB (integrated)  
 22"W x 40"H x 3"E  
 BP: 6"W x 1.25"H x 6"L  
 3000K, CRI 90+, 1830 lm

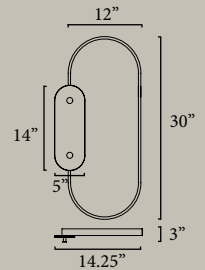

SM24801 • LED Wall Decor

40W LED PCB (integrated)  
 14.25"W x 30"H x 3"E  
 3000K, CRI 90+, 670 lm

Available in Striae Arya with Black (ARYBK)  
 White Alabaster with Black (WABK)  
 White Alabaster with Brushed Champagne (WABCN)

Available in Striae Arya with Black (ARYBK)  
 White Alabaster with Black (WABK)



# REVERIE BY NINA MAGON

Either as a pendant or with a wall-kit installation, the Reverie mirror adds color and interest to this lighting category. Oval-shaped iridescent acrylic panels in deep dichroic hues surround a lighted mirror that can be installed to a base or mounted on a wall with power coming from overhead.

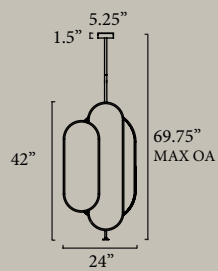

SM24890 • LED Mirror Stand/ Wall Mount

43W DC LED (integrated)  
24"W x 42"H, 2"E, 69.75" MAX OA  
Canopy: 5.25"D x 1.50"H  
3000K, CRI 90+, 2800 lm

Available in Dichroic Glass w/ Black (DCBK)





# TRANCE BY NINA MAGON

Minimalist in design but loud in its statement, oval frames illuminate translucent panels. Available in Natural Aged Brass with Dichroic glass panels, or Gunmetal with a dotted pattern scattered across a translucent glass, the subtleties in the design become more vivid as they react to light. Most notably in the Dichroic glass panels where its iridescent hues become more vibrant with light and the layering effect adds a colorful element to the design. Intentionally designed with various dimensions, the multiple pendant configurations can be fixed together in polygonal cages held by removable clasps or simply free-float on the thin low voltage cables that suspend each frame.



SM24885



SM24883

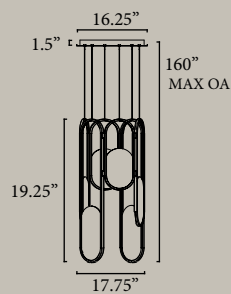

SM24885 • Pendant

102W LED DC (integrated)  
 17.75"D x 39.25"H, 160" Max OA  
 Canopy: 16.25"D x 1.5"H  
 3000K, CRI 90+, 4800 lm

Available in Dichroic Panel  
 w/ Natural Aged Brass(DCNAB) or  
 Gumetal with translucent glass(GM)

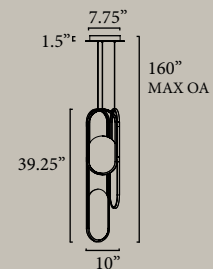

SM24883 • Pendant

14W LED DC (integrated)  
 10"D x 39.25"H, 160" Max OA  
 Canopy: 7.75"D x 1.5"H  
 3000K, CRI 90+, 2640 lm

Available in Dichroic Panel  
 w/ Natural Aged Brass(DCNAB) or  
 Gumetal with translucent glass (GM)



SM24881



SM24882



SM24889

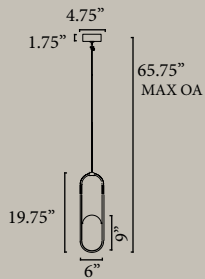

SM24881 • Mini Pendant

14W LED DC (integrated)  
 0.75"W x 19.75"H x 6"L, 65.75" Max OA  
 Canopy: 4.75"D x 1.75"H  
 3000K, CRI 90+, 580 lm

Available in Dichroic Panel  
 w/ Natural Aged Brass(DCNAB) or  
 Gumetal with translucent glass(GM)

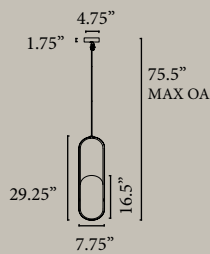

SM24882 • Single Pendant

26W LED DC (integrated)  
 0.75"W x 29.25"H x 7.75"L, 75.5" Max OA  
 Canopy: 4.75"D x 1.75"H  
 3000K, CRI 90+, 1270 lm

Available in Dichroic Panel  
 w/ Natural Aged Brass(DCNAB) or  
 Gumetal with translucent glass (GM)

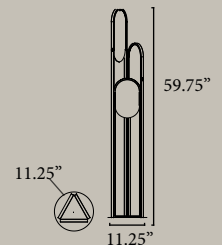

SM24889 • Floor Lamp

69W LED DC (integrated)  
 11.25"W x 59.75"H x 11.25"L,  
 Wire: 72"  
 3000K, CRI 90+, 3360 lm

Available in Dichroic Panel  
 w/ Natural Aged Brass(DCNAB) or  
 Gumetal with translucent glass (GM)





# LOCKET BY NINA MAGON

The alluring visual effect of a milky cloud marble glass provides elegant luminosity. Backlit with evenly diffused LED lighting the fixtures resonate like a vibrant musical note. The fixture is elongated with a vertical metal spike finished in Natural Aged Brass that hugs the glass' shape as it extends in both directions. These elements end in an angle-cut edge which adds visual contrast not only in color but in feeling. The sharpness of a clasp to the softer orb of the marbling white glass. An embodiment of lighting as a jewel, the Locket evokes both the opulence and sentimentality of designer accessories.



SM24875

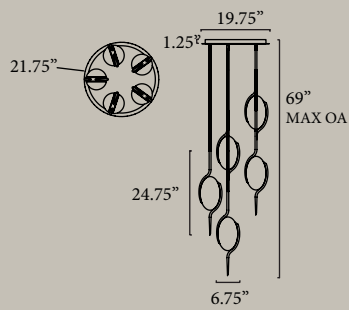

SM24875 • 5lt Multi - Pendant

100W LED PCB (integrated)  
 21.75"D x 24.75"H, 69" Max OA  
 Canopy: 19.75"D x 1.25"H  
 3000K, CRI 90+, 8000 lm

Available in Marble Glass w/Natural Aged Brass (MRNAB)





# DREAMER BY NINA MAGON

Drawing from her acclaimed “Dreamcloud” installation at Art Basel Miami, Nina Magon reimagines her enchanting vision for residential and hospitality interiors. Bringing a sense of ethereal movement and luminous drama to any space, Magon’s signature sweeping curves suspend iridescent bubble-like glass forms that appear to float along channels of LED light. The channels are available in Heritage Brass with Rainbow Iridescent glass or Gunmetal with Mirror Smoked globes. While the design is bold and the colors dramatic, the fixtures manage to coordinate effortlessly with interior spaces and the broader Nina Magon lighting collection.



SM24931



SM24932

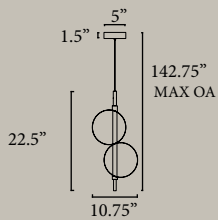

SM24931 • 18" Pendant

6W LED DC (integrated)  
 10.75"W x 22.5"H, 142.75" Max OA  
 Canopy: 5"D x 1.5"H  
 3000K, CRI 90+, 480 lm

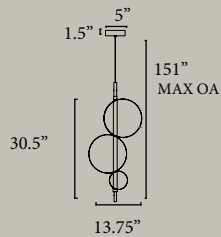

SM24932 • 26" Pendant

9W LED DC (integrated)  
 13.75"W x 30.5"H, 151" Max OA  
 Canopy: 5"D x 1.5"H  
 3000K, CRI 90+, 640 lm

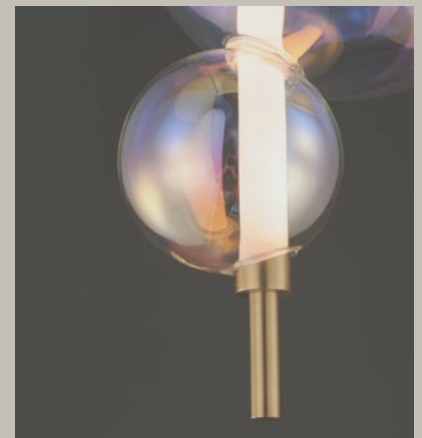

Available in Iridescent w/ Natural Aged Brass (IRNAB)  
 Mirrored Smoke w/Black Chrome (MSKBC)

Available in Iridescent w/ Natural Aged Brass (IRNAB)  
 Mirrored Smoke w/Black Chrome (MSKBC)



# CONTOUR BY NINA MAGON

Gentle curves descend from the ceiling and pop with spheres of satin white glass shades. Strikingly modern, yet elegantly timeless the Contour series exemplifies Nina Magon's design aesthetic using curved silhouettes and bold applications of color. Offered in a variety of rich metallic finishes including Brushed Bronze, Heritage Brass, and Polished Chrome as well as made-to-order powder coat finishes, this collection provides the flexibility to match more spaces. Choose either warm 3000k or bright white 4000k LED lamps included and complete this energy-efficient solution that'll add visual interest to your space that can last generations.



SM24901

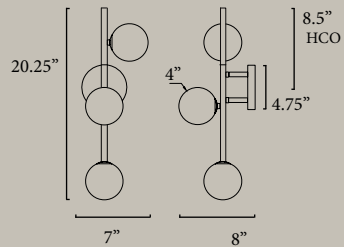

SM24901 • Wall Sconce

(3) 4W LED G9 (included)  
 7" W x 20.25"H, 8"E  
 BP: 4.75"W x 4.75"H, 8.5" HCO  
 BBZ version is 3000K 900 lm, CRI 90+  
 HR version is 3000K 900 lm, CRI 90+  
 PC version is 4000K 900 lm, CRI 90+

Available in Brushed Bronze (BBZ)  
 Heritage Brass (HR) Polished Chrome (PC)





INTRODUCING

# STEFANIE HERING



Studio M proudly partners with Stefanie Hering, to explore the poetry of light through exceptional materials and master craftsmanship.

From the precision of masterfully hand-blown glass and bespoke crystal elements to meticulous, aspirational porcelain produced in Hering Berlin's studio in Germany, every element reflects a dialogue of translucence, reflection, and intention in design. Stefanie Hering's designs harness these qualities to create pieces that glow from within, revealing the quiet drama of light as it passes through and across surface and form.

This collaboration resonates perfectly with Studio M's transformative and experiential ethos, uniting German artistry with Studio M's elevated product capabilities. Together, the two brands present lighting as an immersive experience where material, craftsmanship, and illumination converge to inspire and delight.





# BURGEON BY STEFANIE HERING

Burgeon draws its beauty from the quiet moment just before a flower opens. A softly bloomed porcelain shade cradles light with warmth and intention. Designed by Stefanie Hering, the collection reflects her balance of disciplined German craftsmanship and the expressive soul of Berlin. Housings in brushed metal or marble lend a sense of permanence. Whether portable, pendant, or wall sconce, Burgeon captures stillness, restraint, and the power of quiet elegance..



SM30145



SM30147

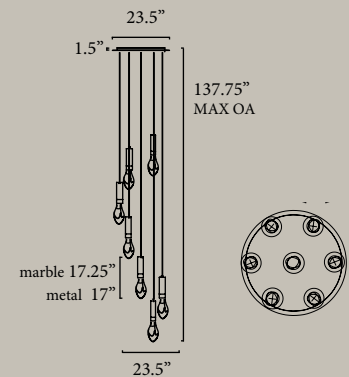
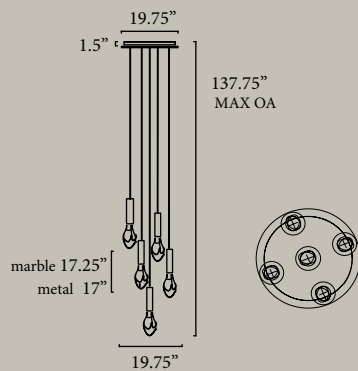

SM30145 • 5lt Pendant

(5) 7W LED DC (integrated)  
 19.75"D x 17" - 17.25"H, 137.75" Max OA  
 Canopy: 19.75"D x 1.5"H  
 3000K, CRI 90+, 1750 lm

SM30147 • 7lt Pendant

(7) 7W LED DC (integrated)  
 23.5"D x 17" - 17.25"H, 137.75" Max OA  
 Canopy: 23.5"D x 1.5"H  
 3000K, CRI 90+, 2450 lm

Available with White Shade with either White(WTWT)  
 Satin Nickle (WTSN) Natural Aged Brass (WTNAB)  
 Verde Alpi Marble w/Natural Aged Brass(WTVAMNAB)  
 Black Marble w/ Natural Aged Brass (WTBKMNAB)  
 White Carara Marble w/ Satin Nickle(WTWCMSN)

Available with White Shade with either White(WTWT)  
 Satin Nickle (WTSN) Natural Aged Brass (WTNAB)  
 Verde Alpi Marble w/Natural Aged Brass(WTVAMNAB)  
 Black Marble w/ Natural Aged Brass (WTBKMNAB) (WTBKMGM)  
 White Carara Marble w/ Satin Nickle(WTWCMSN)



SM30141



SM30143

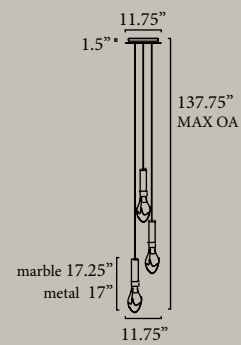
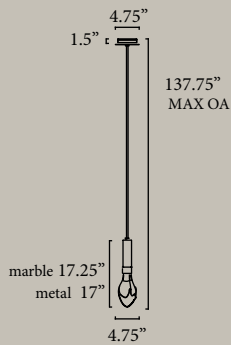

SM30141 • Single Pendant

7W LED DC (integrated)  
 4.75”D x 17” - 17.25”H, 137.75” Max OA  
 Canopy: 6.25”D x 1.5”H  
 3000K, CRI 90+, 350 lm

Available with White Shade with either White(WTWT) Satin  
 Nickel (WTSN) Natural Aged Brass (WTNAB)  
 Verde Alpi Marble w/Natural Aged Brass(WTVAMNAB) Black  
 Marble w/ Natural Aged Brass (WTBKMNAB) White Carara  
 Marble w/ Satin Nickel(WTWCMSN)

SM30143 • 3lt Pendant

(3) 7W LED DC (integrated)  
 11.75”D x 17” - 17.25”H, 137.75” Max OA  
 Canopy: 11.75”D x 1.5”H  
 3000K, CRI 90+, 1050 lm

Available with White Shade with either White(WTWT)  
 Satin Nickel (WTSN) Natural Aged Brass (WTNAB)  
 Verde Alpi Marble w/Natural Aged Brass(WTVAMNAB)  
 Black Marble w/ Natural Aged Brass (WTBKMNAB) (WTBKMGM) White  
 Carara Marble w/ Satin Nickel(WTWCMSN)



SM30149



SM30140

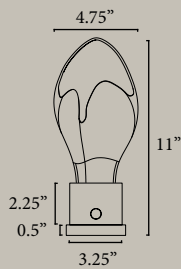

Charger Base (included)

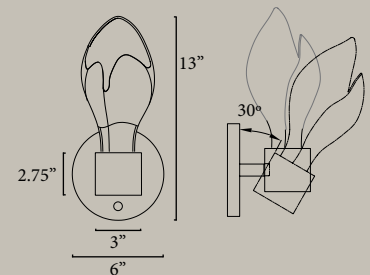

SM30149 • Table Lamp

3W LED DC (integrated)  
 4.75"D x 11"H  
 Dimable Touch switch  
 3000K, CRI 90+, 250 lm

Available with White Shade with either  
 Gun Metal (WTBGM), Satin Nickel (WTSN)  
 or Natural Aged brass (WTNAB)

SM30140 • Wall Sconce

6W LED DC (integrated)  
 6"W x 13"H x 6" E  
 BP: 6"D x 0.75", 10"HCO  
 3000K, CRI 90+, 250 lm

Available with White Shade with either  
 Satin Nickle (WTSN)  
 or Natural Aged brass (WTNAB)



# TROPO BY STEFANIE HERING

Tropo translates the artistry Michelin-starred chefs cherish in Hering Berlin porcelain into illumination. Designed by Stefanie Hering, this chandelier balances a modern abstract silhouette with the timeless grace of a dining-room candelabra. Translucent bone-china shades bathe the table in soft ambient light, while a separately switched downlight provides a focused highlight for plates or centerpieces. Tropo transforms meals into immersive experiences where the subtle drama of light elevates every gathering.



SM300305

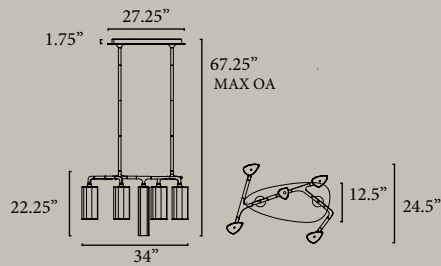

SM300305 • 5lt Pendant

50W LED DC (integrated)  
 24.5"W x 22.25"H x 34"L, 67.25" Max OA  
 Canopy: 12.5"W x 1.75"H x 27.25"L  
 3000K, CRI 90+, 2400 lm

Available in Ombre w/ Vintage Brass(OMBVB)  
 Ombre w/ White(OMBWT) White w/ White(WTWT)  
 White w/ Vintage Brass (WTVB)





SM300307

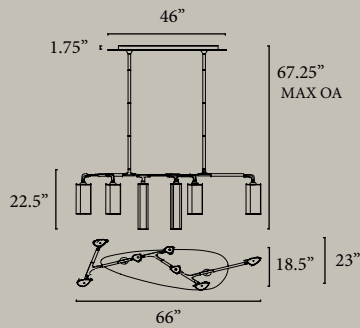

SM300307 • 7lt Pendant

76W LED DC (integrated)  
 23"W x 22.5"H x 66"L, 67.25" Max OA  
 Canopy: 18.5"W x 1.75"H x 46"L  
 3000K, CRI 90+, 3650 lm

Available in Ombre w/ Vintage Brass(OMBVB)  
 Ombre w/ White(OMBWT) White w/ White(WTWT)  
 White w/ Vintage Brass (WTVB)

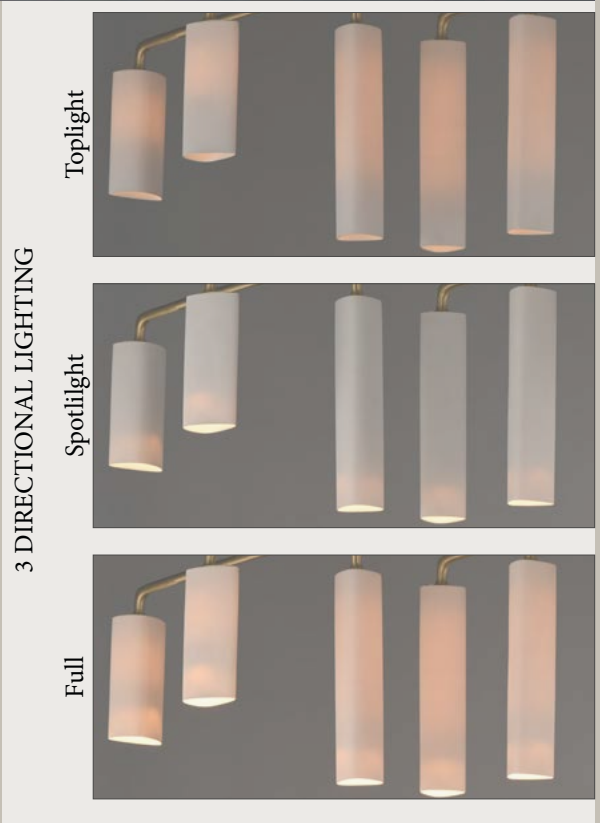



SM300300

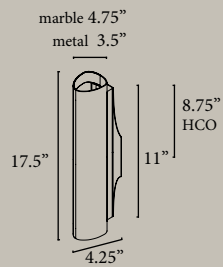

SM300300 • Wall Sconce

10W LED DC (integrated)  
 3.5" - 4.75" W x 17.5" H, 4.25" E  
 BP: 4.75" W x 15.5" H, 8.75" HCO  
 3000K, CRI 90+, 500 lm

Available in Pulse w/Vintage Brass (PLSVB)  
 Pulse w/White (PLSWT) White w/ Vintage Brass (WTVB)  
 White w/White(WTWT)





# STREAM BY STEFANIE HERING

Stream distills quiet luxury into light. First developed in Berlin by Stefanie Hering, the design is elevated by Studio M's advanced LED engineering. Masterfully crafted porcelain shades are offered in three sizes and multiple configurations, from refined singles to modular cascades. Each pendant provides a serene ambient glow, with single pendants also featuring a dedicated LED downlight. Finishes include Bisque Matte White, Ombre Gradient achieved through a burnt-fire technique, and Pulse, a hand-applied concentric relief that showcases Hering Berlin's material mastery.



SM30001-XL-OMBWT



SM30001-L-PLSWT



SM30001-S-WT

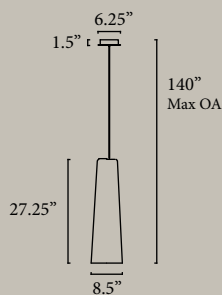

SM30001-XL • Pendant

26W LED DC (integrated)  
8.5"W x 27.25"H, 140"Max OA  
Canopy: 6.25"D x 1.5"H  
3000K, CRI 90+, 1250 lm

Available with shades White (WT)  
Pulse w/White (PLSWT) Pulse (PLSWT)  
Ombre w/White (OMBWT)

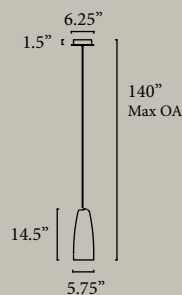

SM30001-L • Pendant

14W LED DC (integrated)  
5.75"W x 14.5"H, 140"Max OA  
Canopy: 6.25"D x 1.5"H  
3000K, CRI 90+, 650 lm

Available with shades White (WT)  
Pulse w/White (PLSWT) Pulse (PLSWT)  
Ombre w/White (OMBWT)

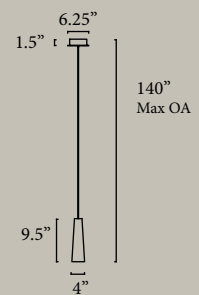

SM30001-S • Pendant

9W LED DC (integrated)  
4"W x 9.5"H, 140"Max OA  
Canopy: 6.25"D x 1.5"H  
3000K, CRI 90+, 450 lm

Available with shades White (WT)  
Pulse w/White (PLSWT) Pulse (PLSWT)  
Ombre w/White (OMBWT)



SM30009



SM30006

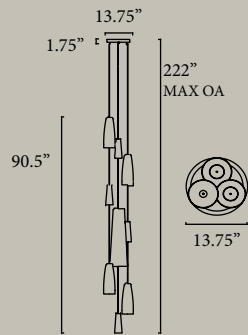

SM30009 • 9lt Chain Pendant

80W LED DC (integrated)  
 13.75"D x 90.5"H, 222" Max OA  
 Canopy: 13.75"D x 1.75"H  
 3000K, CRI 90+, 3840 lm

Available with shades White (WT)  
 Pulse w/White (PLSWT) Pulse (PLSWT)

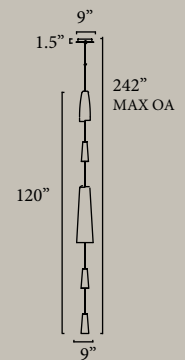

SM30006 • 5lt Chain Pendant

42W LED DC (integrated)  
 9"D x 120"H, 242" Max OA  
 Canopy: 9"D x 1.5"H  
 3000K, CRI 90+, 2000 lm

Available with shades White (WT)  
 Pulse w/White (PLSWT) Pulse (PLSWT)



SM30005



SM30003

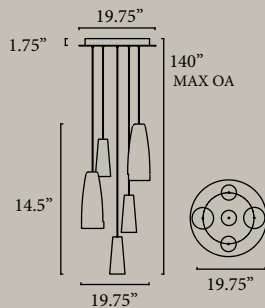

SM30005 • 5lt Pendant

45W LED DC (integrated)  
 19.75"D x 14.5"H, 140° Max OA  
 Canopy: 19.75"D x 1.75"H  
 3000K, CRI 90+, 2200 lm

Available with shades White (WT)  
 Pulse w/White (PLSWT) Pulse (PLSWT)  
 Ombre w/White (OMBWT)

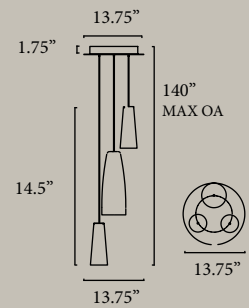

SM30003 • 3lt Pendant

28W LED DC (integrated)  
 13.75"D x 14.5"H, 140° Max OA  
 Canopy: 13.75"D x 1.75"H  
 3000K, CRI 90+, 1350 lm

Available with shades White (WT)  
 Pulse w/White (PLSWT) Pulse (PLSWT)  
 Ombre w/White (OMBWT)



# RAYDANCE BY STEFANIE HERING

Ray Dance explores motion, reflection, and the quiet drama of illumination. Clustered compositions combine fluted glass globes, olives, and "lampion" lanterns in a suspended constellation of light. A faceted crystal refracts light through Clear, Amber, or Smoke glass elements. Offered as single clusters, ring pendants, and a large wall sconce, Ray Dance showcases Stefanie Hering's balance of precision and poetry, transforming glassware artistry into luminous architectural sculpture.



SM49305

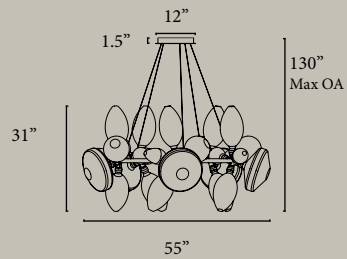

SM49305 • 30lt Cluster Pendant

75W LED DC (integrated)  
 55"W x 31"H x 54"L, 130" Max OA  
 Canopy: 12"D x 1.5"H  
 3000K, CRI 90+, 5400 lm

Available in Black with either Black, Clear (MSCLBK)  
 or Amber/Smoke Glass(EMSKBK)





SM49301



SM49303

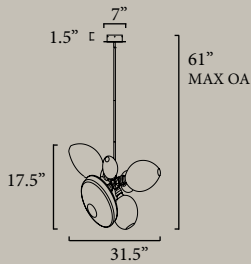

SM49301 • Single Cluster Pendant

15W LED DC (integrated)  
 21"W x 17.5"H x 31.5"L, 61"Max OA  
 Canopy: 7"D x 1.5"H  
 3000K, CRI 90+, 1050 lm

Available in Black with either Black. Clear (MSCLBK)  
 or Amber/Smoke Glass(EMSKBK)

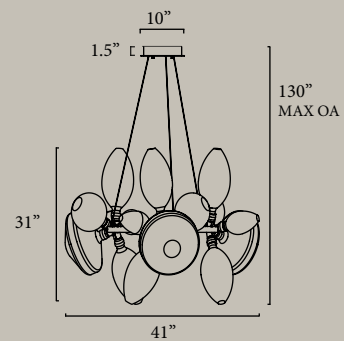

SM49303 • 18lt Cluster Pendant

45W LED DC (integrated)  
 41"D x 31"H, 130"Max OA  
 Canopy: 10"D x 1.5"H  
 3000K, CRI 90+, 3300 lm

Available in Black with either Black. Clear (MSCLBK)  
 or Amber/Smoke Glass(EMSKBK)



SM49311



SM49312



SM49313

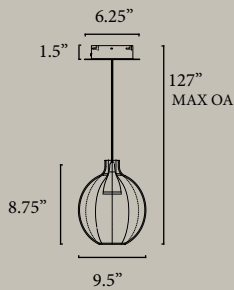

SM49311 • Globe Pendant

6W LED DC (integrated)  
 9.5"D x 8.75"H, 127" Max OA  
 Canopy: 6.25"D x 1.5"H  
 3000K, CRI 90+, 500 lm

Available in Clear (CL) Amber (EM)  
 and Smoke (SMK)

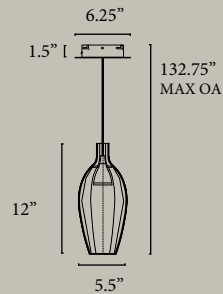

SM49312 • Olive Pendant

6W LED DC (integrated)  
 5.5"D x 12"H, 132.75" Max OA  
 Canopy: 6.25"D x 1.5"H  
 3000K, CRI 90+, 500 lm

Available in Clear (CL) Amber (EM)  
 and Smoke (SMK)

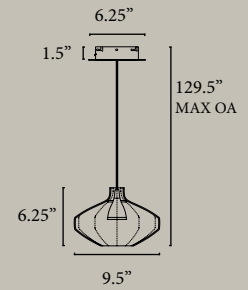

SM49313 • Lampion Pendant

6W LED DC (integrated)  
 9.5"D x 6.25"H, 129.5" Max OA  
 Canopy: 6.25"D x 1.5"H  
 3000K, CRI 90+, 500 lm

Available in Clear (CL) Amber (EM)  
 and Smoke (SMK)



SM49314

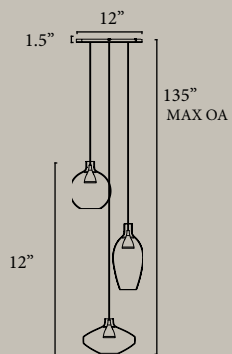

SM49314 • 3lt Multi-Pendant

17W LED DC (integrated)  
13"W x 12"H x 14.5"L, 135" Max OA  
Canopy: 12"D x 1.5"H  
3000K, CRI 90+, 1500 lm

Available in Clear (CL)  
Amber and Smoke(EMSK)





SM49317



SM49315

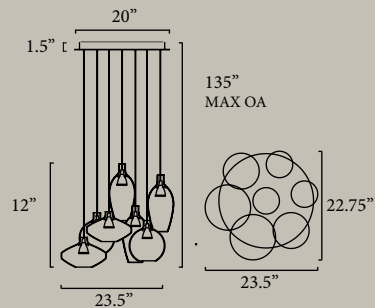

SM49317 • 7lt Pendant

38W LED DC (integrated)  
 23.5"W x 12"H x 22.75"L, 135"Max OA  
 Canopy: 20"D x 1.5"H  
 3000K, CRI 90+, 3500 lm

Available in Clear (CL) Smoke and Clear(MSCL)  
 Amber and Smoke(EMSK)

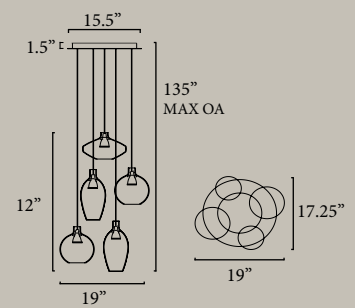

SM49315 • 5lt Pendant

27W LED DC (integrated)  
 19"W x 12"H x 17.25"L, 135"Max OA  
 Canopy: 15.5"D x 1.5"H  
 3000K, CRI 90+, 2500 lm

Available in Clear (CL) Smoke and clear(MSCL)  
 Amber and Smoke(EMSK)



SM49324



SM49325

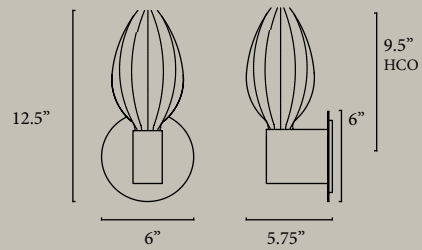
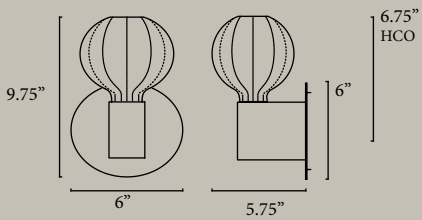

SM49324 • Globe Sconce

SM49325 • Olive Sconce

3W LED DC (integrated)  
 6"W x 9.75"H x 5.75"E  
 BP: 6"D x 0.25"H, 6.75"HCO  
 3000K, CRI 90+, 180 lm

3W LED DC (integrated)  
 6"W x 12.5"H x 5.75"E  
 BP: 6"D x 0.25"H, 9.50"HCO  
 3000K, CRI 90+, 180 lm

Available in Aluminum w/ Clear glass (CLAL)  
 Amber glass (EMAL) or Smoke glass(SMKAL)

Available in Aluminum w/ Clear glass (CLAL)  
 Amber glass (EMAL) or Smoke glass(SMKAL)



SM49300

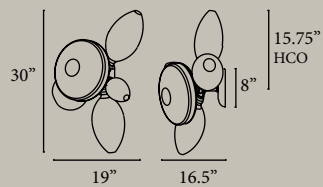

SM49300 • Flush Mount / Wall sconce

13W LED DC (integrated)  
 19"W x 30"H x 30"L, 16.5"E  
 BP: 8"W x 5"H x 1.75"H, 15.75" HCO  
 3000K, CRI 90+, 900 lm

Available in Black with Amber and Smoke glass (EMSKBK)  
 or Black w/Smoke and Clear glass (MSCLBK)





# SODA POP

Thick clear glass globes are hand-blown in organic forms with irregular bubble patterns. The profiles are small and can be installed singularly or in groupings for a unique configuration on wall and ceiling surfaces. The metal accents are finished in Polished Chrome to add reflection to the composition of the shades that encase an LED light source within. Three size options available. ADA options are also available. Neutral 3000K Color Temperature.



SM25390



SM25391



SM25392

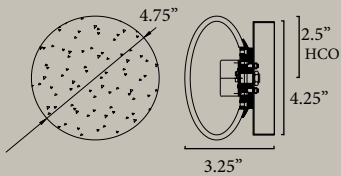

SM25390 • 5" Vanity

6W LED PCB (integrated)  
 4.75"W x 4.75"H x 3.5"E  
 BP: 4.25"W x 4.25"H, 2.5" HCO  
 3000K CRI 90+, 260 lm

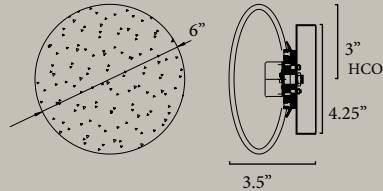

SM25391 • 6" Vanity

6W LED PCB (integrated)  
 6"W x 6"H x 3.5"E  
 BP: 4.25"W x 4.25"H, 3" HCO  
 3000K, CRI 90+, 260 lm

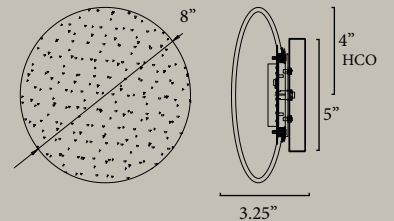

SM25392 • 8" Vanity

10W LED PCB (integrated)  
 8"W x 8"H x 3.5"E  
 BP: 5"W x 5"H, 4" HCO  
 3000K, CRI 90+, 700 lm

Available in Polished Chrome with  
 Bubble Glass (BGPC)

Available in Polished Chrome with  
 Bubble Glass (BGPC)

Available in Polished Chrome with  
 Bubble Glass (BGPC)

LSMCAT2601

STUDIO M  
LIGHTING

[studiomlighting.com](http://studiomlighting.com)